



LEVEL SWITCH

CV120/CV130/CV140/CV150

Tough and reliable vibrating level switch for bulk solids.
High versatility: applicable for many materials: heavy or lightweight, granular or powdered.

Description

The **LEVELSWITCH** is a level control device for the detection of minimum and maximum levels in bins, silos and hoppers. It is designed to detect all kinds of grained, granular or powdered bulk solids. Typical applications are overflow protection and indication of high-, mid- or low-level alarm.

Advantages

- **Vibration technique**
The piezo driven vibration technique, offers many advantages over alternative level sensing technologies:
 - no moving parts: high durability
 - no maintenance required
 - unaffected by environmental changes e.g. temperature, pressure, humidity
 - unaffected by material changes
 - unaffected by dust clouds and agitation
 - no calibration required
 - maximum versatility
 - the vibration has a self cleaning effect

 - **Single blade design**
 - The special design where only one rod comes in touch with the material to be detected prevents material bridging, a failure that is typically associated with the dual blade „tuning fork“ design.
-
- Extremely sensitive: the **LEVELSWITCH** can be used for extremely lightweight material with densities as low as 20 grams / liter.
 - Strong stainless steel construction with patented reinforced membrane makes the **LEVELSWITCH** tough for the use with heavy material such as cement.
 - Material build-up on the container wall has no influence on the function of the **LEVELSWITCH** as only the tip of the vibrating blade is sensitive and not the base.
-
- **Highest quality**
 - latest state-of-the-art piezoelectric technology
 - solid stainless steel construction
 - designed and manufactured at PTL in Germany according to DIN EN ISO9001:2008 with the background of more than 25 years of experience in the field of level control.

Function and Application

The vibrating system of the **LEVELSWITCH** gets forced to vibrate on its resonance frequency by a piezo crystal drive. If filling material, (bulk solids), covers the vibrating blade of the probe, its vibration gets damped. This is sensed by the electronic circuitry which forces its output to switch. When the blade gets uncovered due to declining level, the probe restarts to vibrate and the output switches back.

Because of its maximum versatility the **LEVELSWITCH** is ideal for applications where contents changes are common since the instrument must not be calibrated according to the characteristics of the material.



The following list shows some of the material the **LEVELSWITCH** has been successfully used for:

powdered milk	tea (leaf)	wood shavings
frozen chips	salt	chalk
beans	flour	styrofoam
sugar	spices	cellulose
sweets	soda	glass ground
coffee beans	pellets	granular plastics
coffee ground	animal food	powdered clay
peanuts	carbon black	polystyrene
tobacco	chemicals	gravel
cement	foundry sand	sawdust

Models

- Standard model: **LEVELSWITCH CV120**

The CV120 is designed for top- or side-mounting. It has a fixed insertion length of approx. 173mm. Connection to the container is made via thread 1 ½" DIN 2999 (equals BSPT) or NPT.



- Pipe extension welded: **LEVELSWITCH CV130**

If the application requires longer insertion lengths the CV130 is the right choice.

This model offers the possibility to adapt the insertion length exactly to the application by means of a pipe which is welded between the vibrating probe and the 1½" mounting socket. Maximum insertion length for CV130 is 2,0 meters.



The CV130 is suitable for top mounting. Side mounting is possible for insertion lengths shorter than 1 meter and if the extension pipe is adequately supported. Connection to the container is made via thread 1 ½" DIN 2999 (equals BSPT) or NPT.

Alternatively the CV130 is available with process connection "Tri-Clamp" according to DIN32626.

- Extension by threaded pipe: **LEVELSWITCH CV140**

The CV140 provides the possibility of insertion lengths up to 4,0 meters. The extension is performed by a 1" pipe with threads on both ends. This pipe simply gets screwed between the vibrating probe and the 1½" mounting socket.

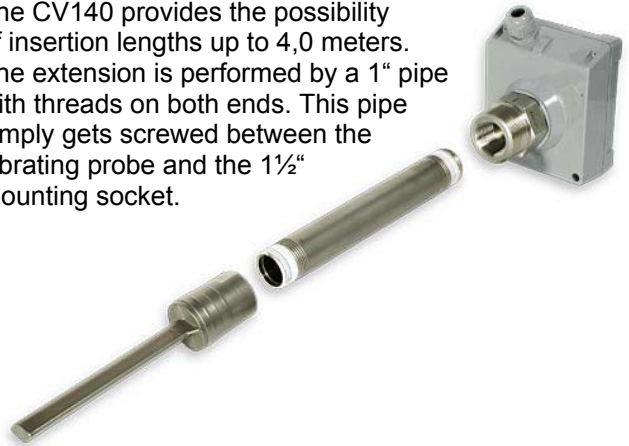

As no special equipment is necessary for making the extension it is possible that the customer obtains and mounts the extension tube at the site which helps to save costs for equipment and transport. The CV140 is suitable for top mounting. Side mounting is possible for insertion lengths shorter than 1 meter and if the extension pipe is adequately supported. Connection to the container is made via thread 1 ½" DIN 2999 (equals BSPT) or NPT. The type of the 1" inside thread for the extension tube (DIN or NPT) equals the type of the 1½" outside thread for process connection.

- Flexible cable extension: **LEVELSWITCH CV150**

The CV150 allows insertion lengths up to 20 meters. The extension is performed by means of a polyurethane sheathed, steel rope reinforced cable.

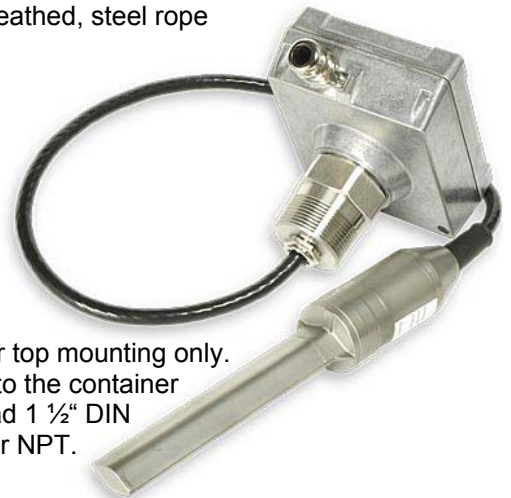

The CV150 is for top mounting only. The connection to the container is made by thread 1 ½" DIN (equals BSPT) or NPT.

The CV150 has not only the advantage that very long insertion lengths can be realized but additionally provides easy transport as it can be shipped in very compact boxes in comparison to the extension tube models CV130 and CV140.

➤ Remote electronics installation

At some applications it is necessary to keep the electronics separated from the container. This is the case at very high temperatures or heavy vibrations or shocks. The remote electronics installation is possible for all **LEVELSWITCH** models. The standard length of the cable extension is 2 meters. Longer cables are available as well.



➤ High temperature model

The standard **LEVELSWITCH** is designed for process temperatures of max. 80°C. At temperatures up to 150°C, the high temperature model must be used which is available for CV120, CV130 and CV140. To protect the electronics from too high temperatures, a temperature insulating tube gets mounted in between the mounting socket and the enclosure. Instead it is as well possible to install the electronics at a place with lower ambient temperature by using the remote electronics installation.

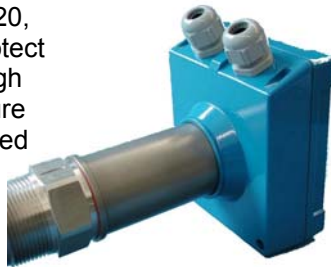

➤ special model "Extreme Sensitivity"

This special model is designed for applications where extremely light material with densities down to 10g/l has to be detected.

Options

The following options are available:

- second cable gland M20 x 1,5 (not available in combination with remote electronics installation)
- enclosure powder coated grey, blue, orange or beige
- externally visible LED for indicating relay status (not in combination with ex approval)
- process connection "Tri-Clamp" according to DIN32626, (available for CV130 only)
- test facility: function test to be performed when probe is vibrating: the vibration can be stopped by closing a contact. The output of the electronics switches accordingly enabling the test of all further signals and actions.
- Ex approvals according ATEX directive 94/9/EC for CV120, CV130, CV150: dust-ex and gas-ex

Approvals

- CE-approval for all instruments according to the following directives:
 - EMC-directive 2004/108/EG
 - Low Voltage-directive 2006/95/EG
- Ex-approval according to ATEX 94/9/EC available for CV120, CV130 and CV150:
 - Dust-Ex: ATEX II 1/2D Ex ta/tb IIIC T95°C Da/Db for zones 20/21/22
 - Gas-Ex: ATEX II 1G Ex ia IIB T4 Ga
or ATEX II 1/2G Ex ia IIB T4 Ga for zones 0, 1 or 2

For detailed information see page 6 and 7.

Specifications

Enclosure: die cast aluminum, (option powder coated)
 protection IP 66 and IP 67 (IP65 for remote electronics installation)
 1 cable gland M20 x 1,5 (option: second cable gland)

Electronics: **Wide range power supply 20 ... 250V AC/DC with relay output:**
 two potential-free change-over contacts (DPDT)
 max. switching datas AC: 250V-AC, 8A, 2000VA, $\cos\phi = 1$
 max. switching datas DC: 8,0A at 24V-DC / 1,5A at 48V-AC
 min. switching datas DC: 24V / 100mA
 Power consumption: < 3 VA

or: **power supply 24V-DC with transistor output (3-wire):**
 potential free, NPN or PNP type
 350mA @ 24V-DC, shorttime max. 1A, max. power 20W
 power loss max. 3V, max. leakage current 100 μ A; short circuit proof
 power consumption at blocked transistor: < 1 W

or: **power supply 20...30V-DC with 8/16mA-output (2-wire):**
 power consumption: < 0,5 W
 The probe can be supplied by the supply and analyzing unit CV2000AE e.g.
 Gas-Ex approval with protection concept *intrinsic safety* is available for this version.

Time Delay: 1 second from stop of vibration
 2 to 5 seconds for start of vibration

Indication: LED on PCB (option: externally visible)

Probe: Material: stainless steel 1.4301 / AISI 304
 Extension cable CV150: polyurethane sheathed

connection: - thread 1 1/2" DIN 2999 (equals BSPT) or 1 1/2" NPT
 - process connection "Tri-Clamp" according to DIN32626
 (available for CV130 only)

resonance frequency: approx. 285 Hz
 max. horizontal load upon the end of the blade: 150 N
 max. vertical load upon the end of the blade: 1000 N
 max. tensile load of cable CV150: 200 kg

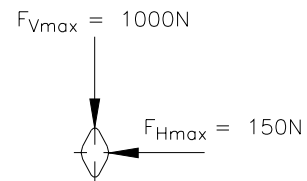

Material to be detected: non sticky bulk solids
 min. density 20 grams per litre, with special model as low as 10 g / litre
 grain size from powder to max. 40mm

max. pressure inside bin: 10 bar

ambient temperature electronics: -40°C ... + 60°C

process temperature: probe: -40°C ... + 80°C (CV150: max. 70°C)
 probe HT: -40°C ... + 150°C



Products with ATEX Approval: Protection Level, Marking, Zones

➤ **Dust-Ex, Protection by Enclosure: CV120StEx, CV130StEx, CV150StEx**

The vibrating level switches CV120StEx/CV130StEx/CV150StEx can be used in the presence of combustible dust according to ATEX directive 94/9/EC: equipment group II, category 1/2D or 1/3D for remote electronics installation.

Marking according to directive 94/9/EC:

The vibrating level switches CV120StEx / CV130StEx / CV150StEx have a nameplate on the enclosure showing the following data:
 e.g: CV120 StEx with wide range power supply, standard unit, (no high temp)

	PTL Hermann GmbH Kellermatten 3 - 79618 Rheinfelden - Germany - info@ptl-hermann.com www.ptl-hermann.com	
		Level Switch CV120DIN-StEx Ser.No.: xxxxxxStEx
	II 1/2D Ex ta/tb IIIC T95°C Da/Db Tamb (Gehäuse, Zone 21): -20..+60°C	Power Supply: 20...250V AC/DC Relay Output: max. 8A @ 250V Power Consumption: 3 VA IBExU03ATEX1033 IP6X Tprocess (Sonde, Zone 20): -20..+80°C

Allocation of Categories, EPL and Zones:

Component	Category	EPL Equipment Protection Level	can be used in Zone
Probe	1 D	Da	20, 21 or 22
Enclosure with PCB	2 D	Db	21 or 22
Remote Electronics Installation	3 D	Dc	22

Protection according to EN 60079-31:

- protection by dust-tight enclosure IP6X
- limited surface temperatures of the apparatus

Maximum surface temperatures:

Zone	max. permissible amb. temperature	max. surface temperature at failure	heat up due to failure
Zone 20	80°C for standard units 70°C for CV150 150°C for high temperature (= process temp.)	80°C for standard 70°C for CV150 150°C for high temp	0 K 0 K 0 K
Zone 21/22	60°C	95°C	+35 K

The 35K maximum heat up of the enclosure surface results on 25K heat up of the electronics at failure and additional 10K due to heat conduction via the probe in cases the process temperature is higher than 60°C.

➤ **Gas-Ex, Protection Concept Intrinsic Safety: CV120Exi, CV130Exi, CV150Exi**

The vibration type level switches CV120Exi / CV130Exi / CV150Exi have approval according to ATEX directive 94/9/EC for the use in explosive atmospheres as follows:

- Gas-Ex: II 1 G Ex ia IIB T4 Ga or II 1/2G Ex ia IIB T4 Ga
- Dust-Ex: II 1 D Ex ia IIIC TX Da or II 1/2D Ex ia IIIC TX Da

Architecture

The units come with a split architecture allowing the probe with low energy 8/16mA-output to be installed within the explosive atmosphere whereas the supply and analyzing unit CV2000AE[Exi] with wide range power supply and relay output must be installed at the non explosive area.

For installation it is important to know that the associated apparatus CV2000AE[Exi] is not galvanically isolated. Special requirements according to EN60079-14 have to be considered.

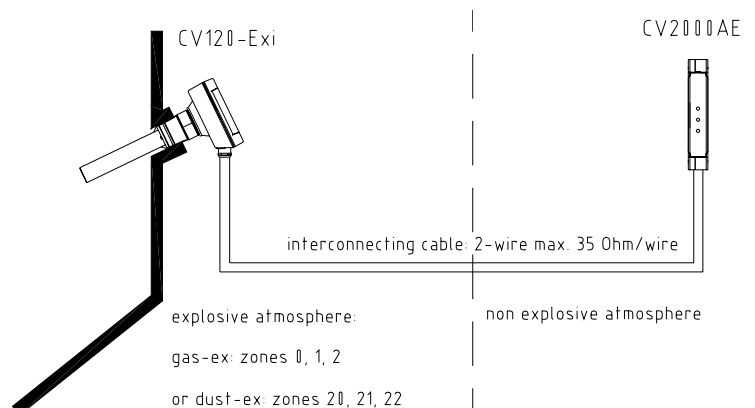

Applied standards: EN60079-0, EN60079-11, EN60079-26, EN60079-31.

Marking according ATEX directive 94/9/EC:

The units have a nameplate showing the following details:

e.g. Cat. 1 apparatus CV120Exi

	PTL Hermann GmbH		www.ptl-hermann.com
	Kellerplatten 3 - 79618 Rheinfelden - Germany		info@ptl-hermann.com
	Level Switch CV120DIN-Exi Ser.No.: xxxxxxExi		Ui=23,7V-DC
	IBExU09ATEX1005X		li=167mA
	II 1G Ex ia IIB T4 Ga	II 1/2G Ex ia IIB T4 Ga	Pi=958mW
	II 1D Ex ia IIIC TX Da	II 1/2D Ex ia IIIC TX Da	Ci: neglig.; Li: neglig. Ta=-20...+60°C IP6X

Allocation of Categories and Zones:

Apparatus type	Marking	Component	Category	for Gas-Ex Zones	for Dust-Ex Zones
Cat.1-apparatus	1G Ex ia IIB T4 Ga 1D Ex ia IIIC TX Da	Probe	1G or 1D	0, 1 or 2	20, 21 or 22
		Encl. with electronics	1G or 1D	0, 1 or 2	20, 21 or 22
Cat.1/2-apparatus	1/2G Ex ia IIB T4 Ga 1/2D Ex ia IIIC TX Da	Probe	1G or 1D	0, 1 or 2	20, 21 or 22
		Encl. with electronics	2G or 2D	1 or 2	21 or 22

Allowed ambient temperatures Tamb:

Apparatus type	Unit type	Temp.-class	max. surface temperature	Tamb at electronics	Tamb at probe without temp. insul. tube	Tamb at probe with temp. insul. tube
Cat.1-apparatus	Standard units CV120Exi/CV130Exi/ CV150Exi	T4	Probe: 60°C Encl.: 75°C	-20 ... +60°C	-20 ... +60°C	combination not available
Cat.1/2-apparatus	Standard units CV120Exi/CV130Exi/ CV150Exi	T4	Probe: 60°C Encl.: 85°C	-20 ... +60°C	-20 ... +80°C	combination not available
	High temp. units CV120Exi-HT CV130Exi-HT	T4	Probe: 108°C Encl.: 85°C	-20 ... +60°C	combination not available	-20 ... +108°C *
	High temp. units CV120Exi-HT CV130Exi-HT	T3, T2, T1	Probe: 150°C Encl.: 85°C	-20 ... +60°C	combination not available	-20 ... +150°C *

* listed temperatures already include reduction to 80% according to EN1127-1 chpt. 6.4.2

Technical data referring to intrinsic safety:

- Ui=23,7V, li=167mA, Pi=958mW, Li: negligible, Ci: negligible
- Power supply and signal conversion is made by the associated apparatus CV2000AE[Exi].

Special requirements according to EC-Type Examination No. IBExU09ATEX1005X:

- For functional reasons the probes are connected to earth. The enclosure of the apparatus must be connected to the equipotential bonding system.
- Special requirements for associated apparatus without galvanic isolation according EN 60079-14 have to be observed.
- In case the units are used as category 1 apparatus in zones 0 or 20 the units must be installed in a way that the generation of sparks due to friction or strokes on the aluminium housing is eliminated.
- The allowed temperature range and the mounting instructions according to the instruction manual have to be observed.
- In case the units are used as category 1 / 2 apparatus at gas explosive atmospheres the 1 1/2" thread which serves for process connection and separation of zones 0 and 1 must be sealed in a way that protection IP67 according to EN60529 is achieved.

CV2000AE[Exi]

The CV2000AE is a supply and analysing unit for the vibration type level switches STOCKTROL CV210/310/410/510 with 8/16mA output. For the intrinsically safe probes CV210Exi / CV310Exi / CV510Exi the CV2000AE [Exi] has approval according to ATEX 94/9/EC as the associated apparatus.



Function:

The CV2000AE supplies the connected vibration type level switch with a DC voltage. Depending on the level inside the bin, (probe covered with filling material or not), the electronics of the probe takes more or less current. This current change is sensed by the CV2000AE and gets converted into a relay output. The interconnecting cable between probe and CV2000AE gets monitored permanently for short circuit and line break. In case of short circuit or line break an additional relay output switches.

Technical Data:

Enclosure: Polyamid enclosure for carrier rail mounting 35mm according to EN50022 dimensions 114x35x99mm; protection IP20

Electronics: Power Supply: 20...250V AC/DC; max. 3VA
 Output power supply for probe: 20V-DC (without load)
 Relay Output: one potential free change over contact (SPDT), max. 5A/250V
 Failure indication: detection of line break and short circuit by add. relay max. 5A/250V
 Connection cable to probe: 2-wire, max. 35 Ohms per wire
 Indication: yellow LED: power supply
 green LED: relay status
 red LED: failure indication (line break and short circuit)

Temperature: -20°C ... + 60°C

Approvals:

The CV2000AE meets the following European directives: - EC EMC directive 2004/108/EC
 - EC low voltage directive 2006/95/EC

The following standards have been applied: - EN 61326 05.04
 - EN 61010-1



The CV2000AE [Exi] has approval according to ATEX 94/9/EC as the associated apparatus for intrinsically safe vibration type level switches as follows:

Gas: II (1)G [Ex ia Ga] IIB

Dust: II (1)D [Ex ia Da] IIIC

	PTL Hermann GmbH		www.ptl-hermann.com
	Kellerplatten 3 - 79618 Rheinfelden - Germany		info@ptl-hermann.com
	CV2000AE [Exi]	Power Supply: 20..250V AC/DC	
0044	Ser.No.: xxxxxxExi	Power Consumption: 3VA	
	II (1) G [Ex ia Ga] IIB	U ₀ =23,7V; I ₀ =166mA; U _m =375V	
	II (1) D [Ex ia Da] IIIC	Co=390nF; Lo=4,3mH, Kennlinie linear	
	IBExU09ATEX1006 X		Ta=-20 ... +60°C

Special requirements according to EC-Type Examination No. IBExU09ATEX1006X:

According to the EC-Type Examination Certificate of the CV2000AE [Exi] the following special requirements have to be fulfilled:

At the installation the additional requirements for associated apparatus without galvanic isolation according to EN 60079-14 have to be considered.

Dimension

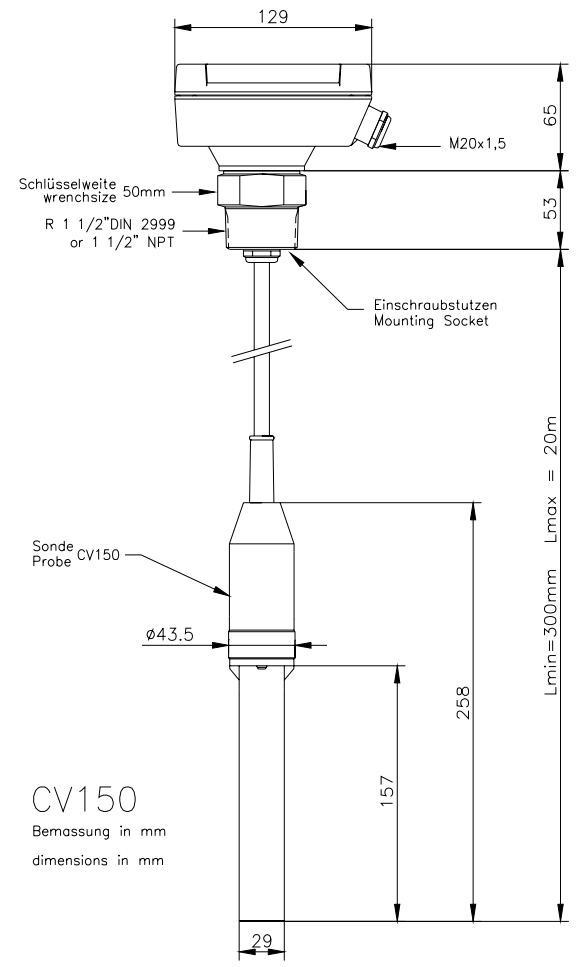
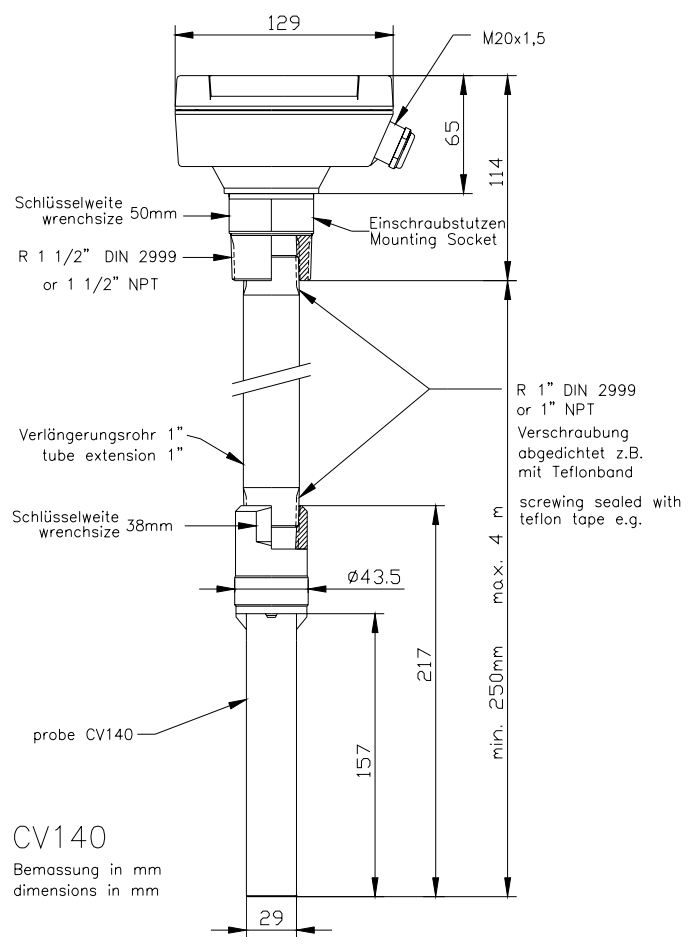
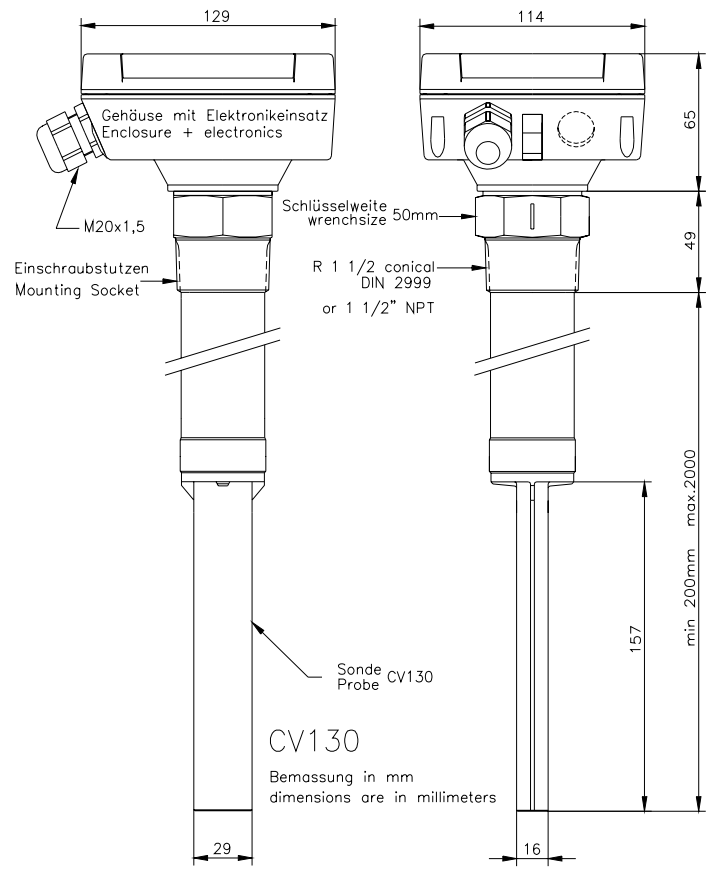
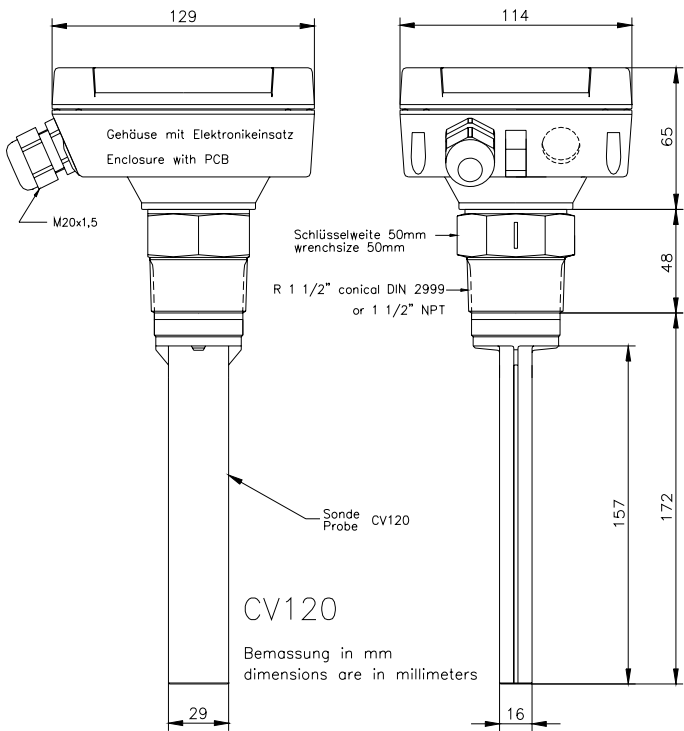

➤ Remote Electronics Installation

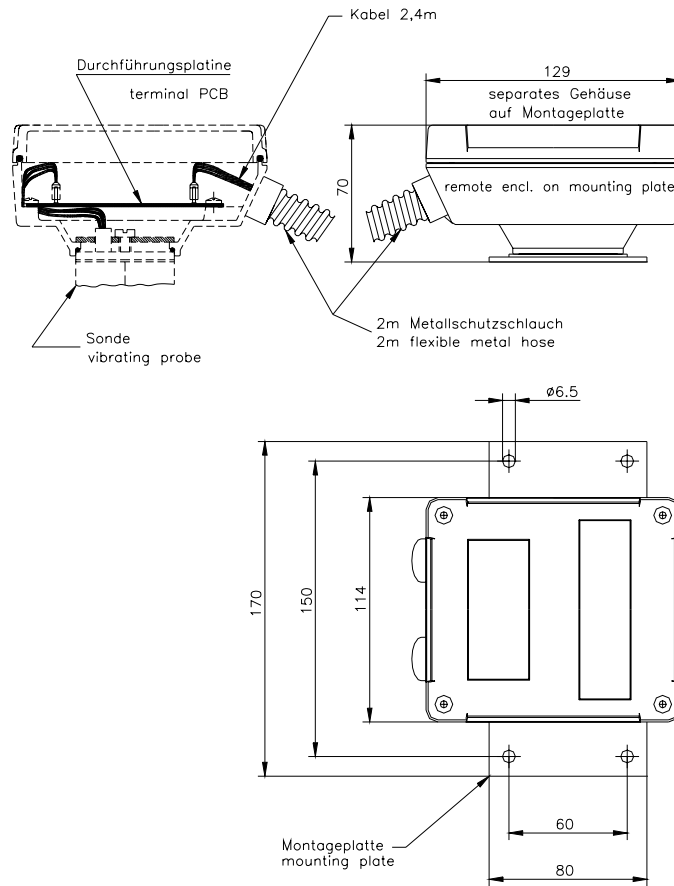

➤ Special Model HT with Temperature Insulating Tube

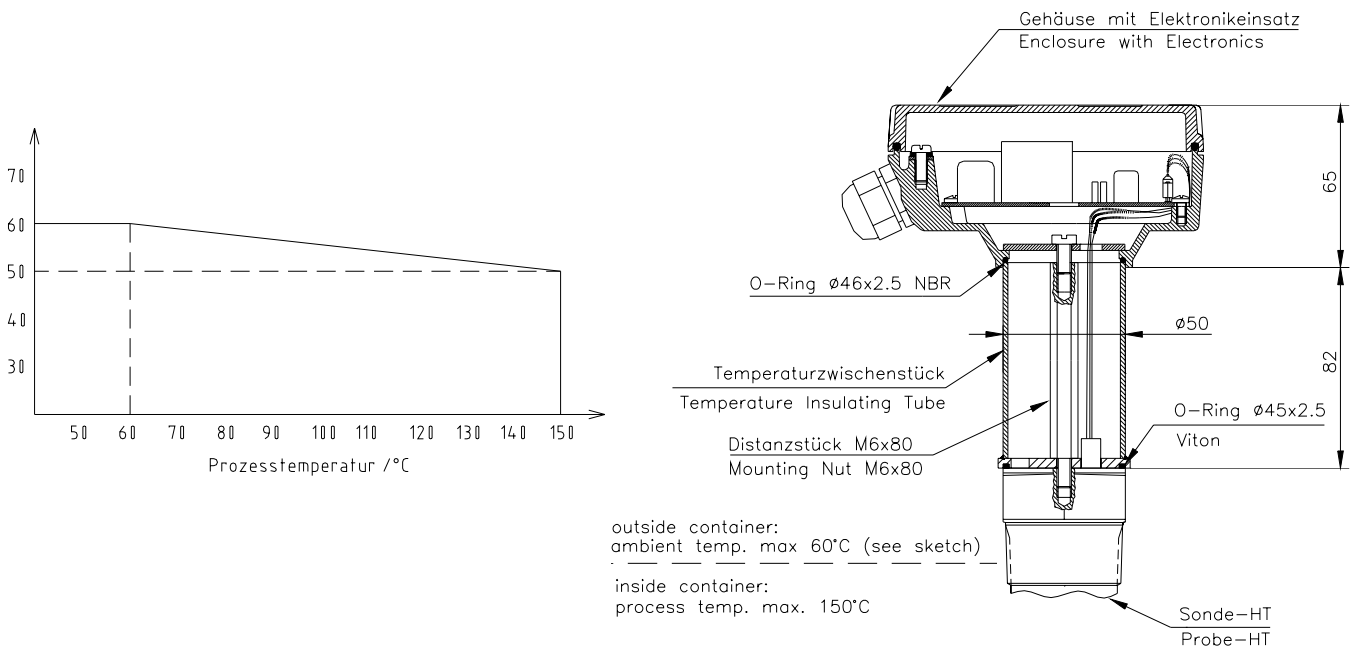

➤ CV2000AE

